

Autoclave and tooling effects

Project done by:

UBC and CMT

Project funded by:

NSERC, CMT

Summary:

Using COMPRO, a study of the effect of tooling material and autoclave heat transfer coefficient is performed. It is found that not all autoclaves are the same and that heat transfer coefficients are pressure dependent. It is shown that the thermal mass of the tool plays a big role in cycle times and that springback is dependent on the cure cycle, but can be predicted with reasonable accuracy using process modelling.

References:

- *Fernelund G, Rahman N, Courdji R, Bresslaur M, Poursartip A, Willden K, Nelson K. [Experimental and Numerical Study of the Effect of Cure Cycle, Tool Surface, Geometry and Lay-Up on the Dimensional Fidelity of Autoclave-Processed Composite Parts](#) - Comp Part A 2002: 33; 341-351

Case Study I

This case study investigates the effect of tool material and autoclave characteristics on cycle time and temperature profiles:

Tool materials studied

Aluminum

Invar 36

Autoclave characteristics based on measurements

A: good heat transfer characteristics

B: poor heat transfer characteristics

FE model: composite angle

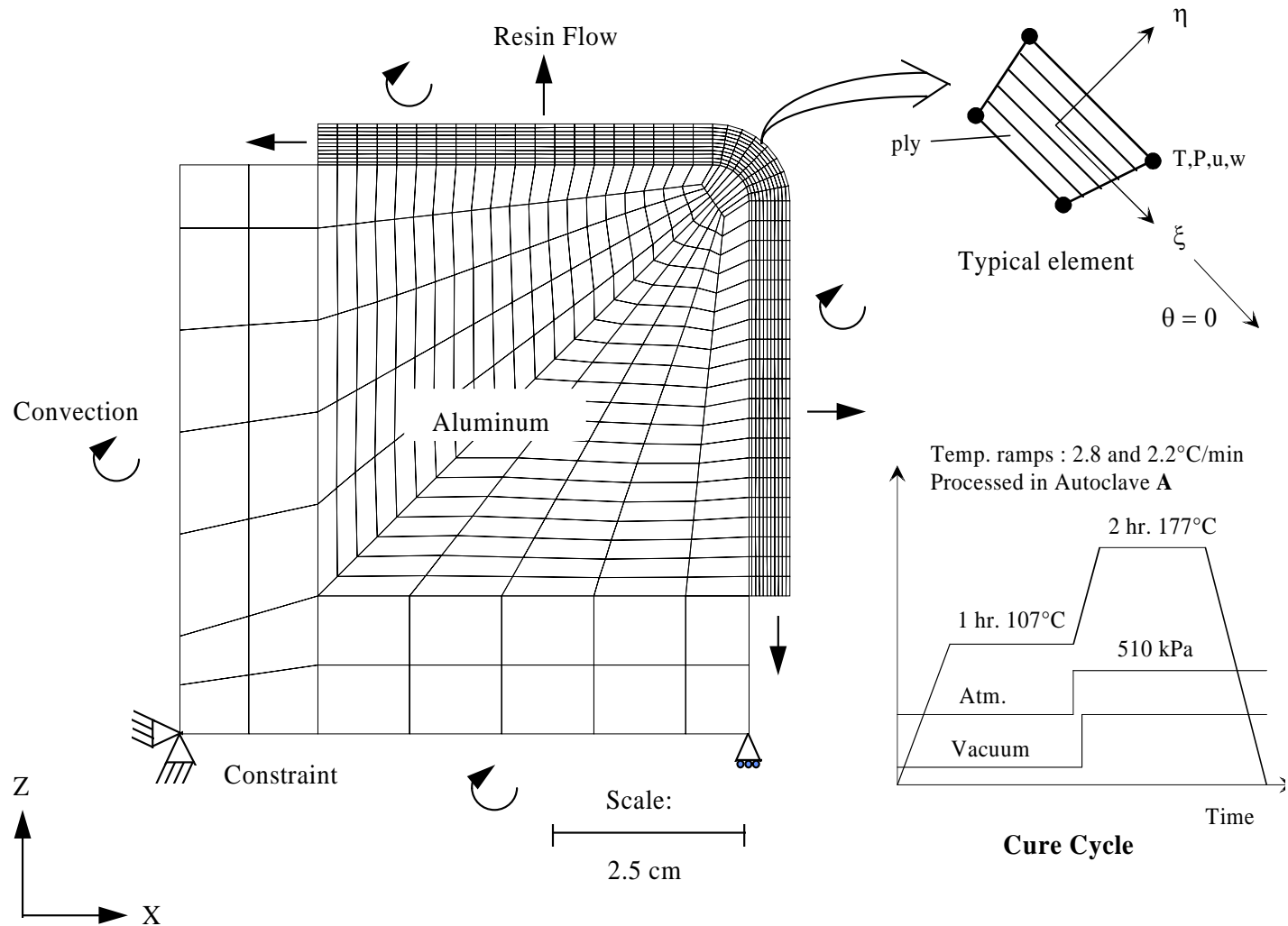

Predicted temperature and cure

Autoclave A: good heat transfer

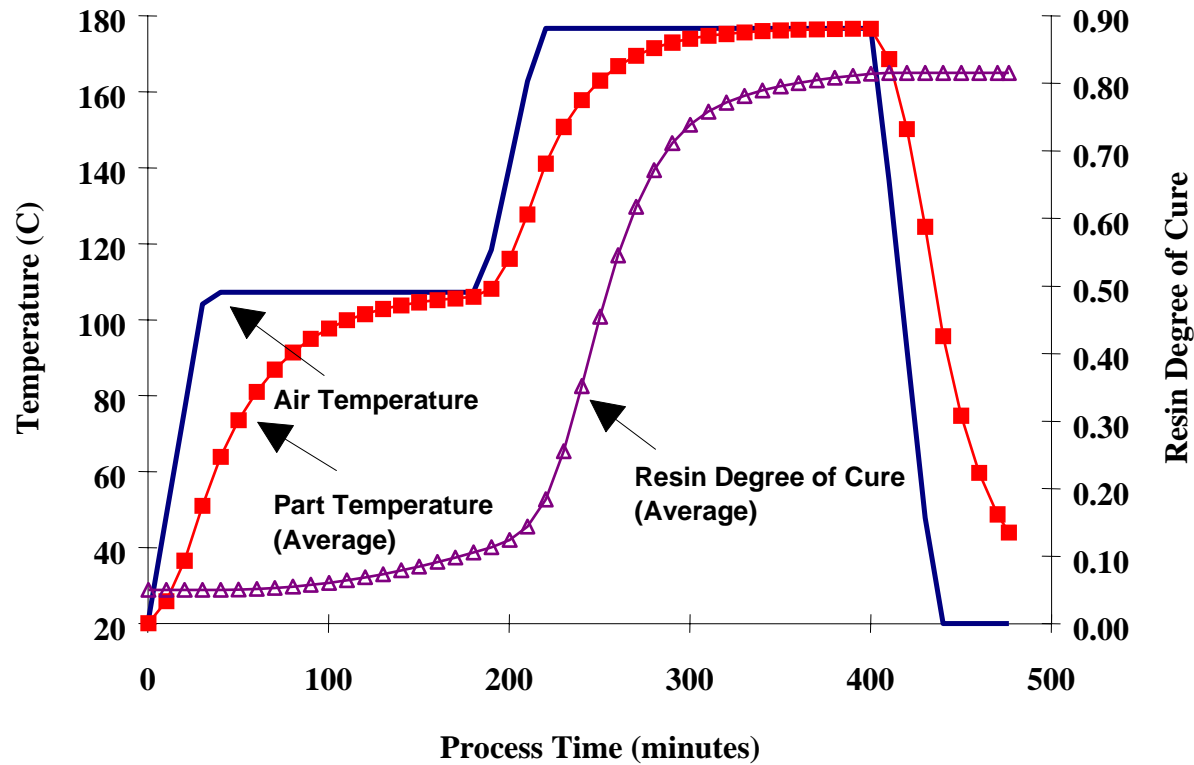

Temperature predictions gradients during ramp

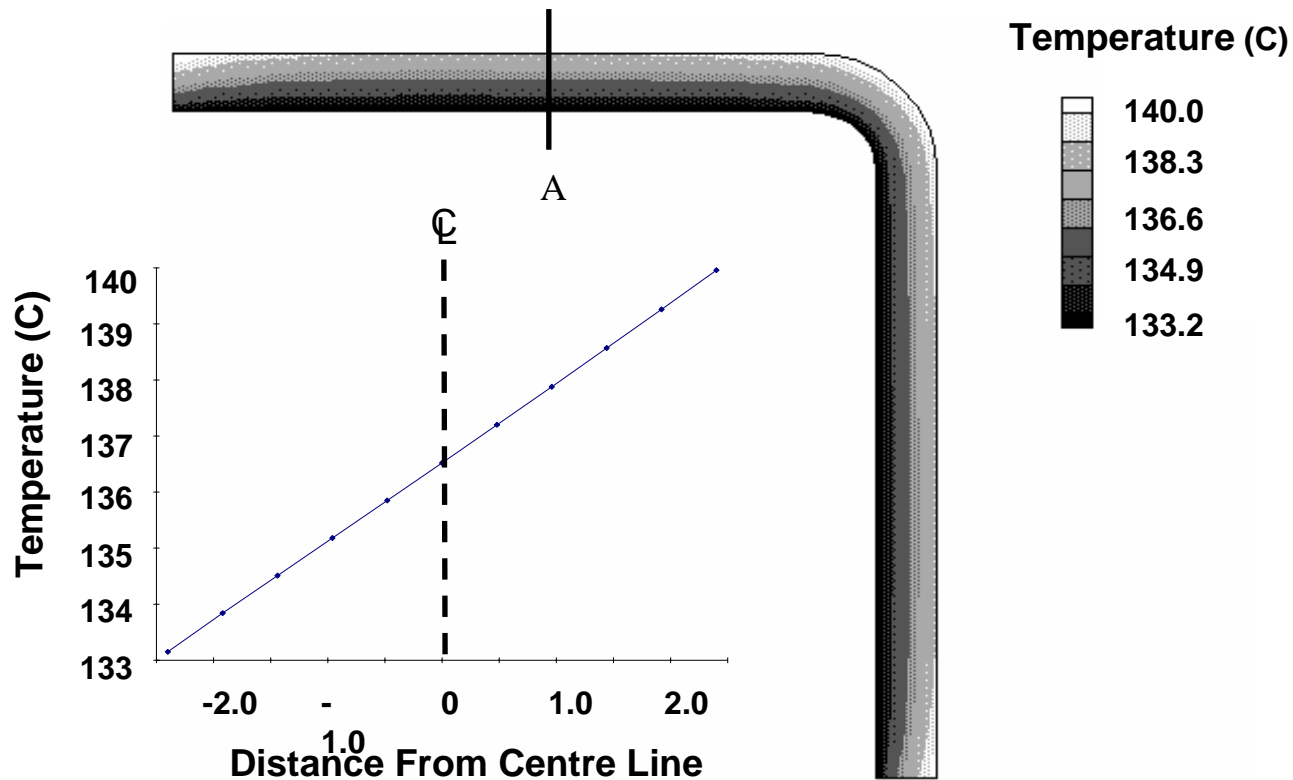

Effect of tool material on cycle length

lead-lag control employed

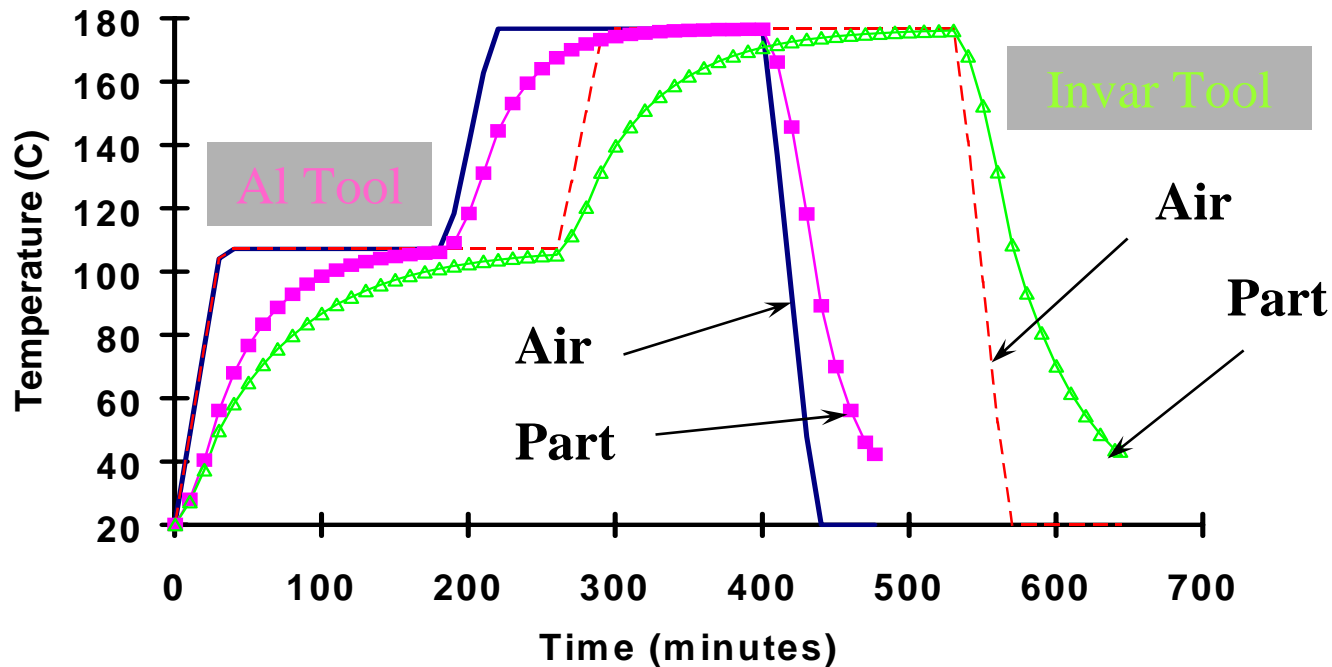

Heat transfer coefficient characterization

Tests performed:

- Rate of heat transfer to thick aluminum plates measured
- Effect of autoclave pressure and temperature examined
- Experimental set-up

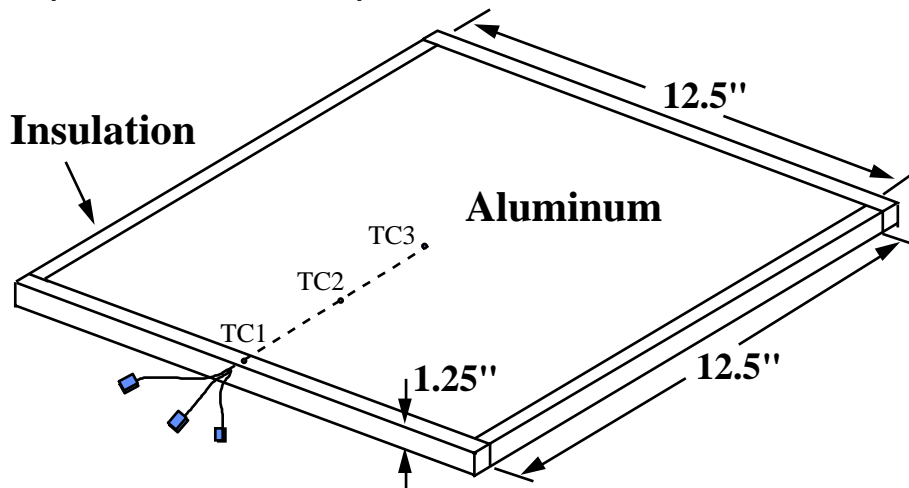

Four different autoclaves tested:

Autoclave	Primary Usage	Dimensions
Industry1	Production	6 ft. dia x 15 ft. long
Industry2	Development	5 ft. dia x 8 ft. long
Industry3	Production	> 20 ft. dia x 60 ft. long
UBC	Development	3 ft. dia x 6 ft. long

Autoclave heat transfer coefficients

(results from two different autoclaves)

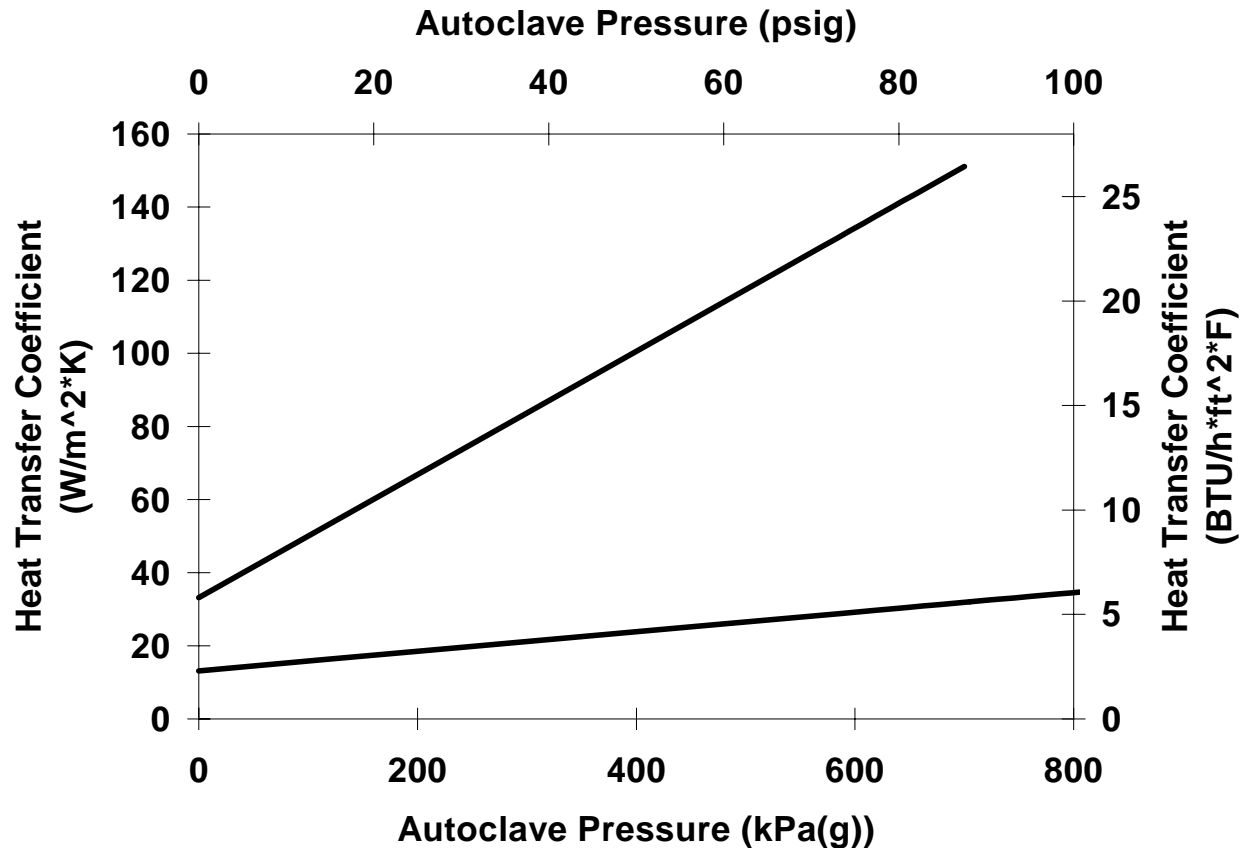

Effect of autoclave on cycle time

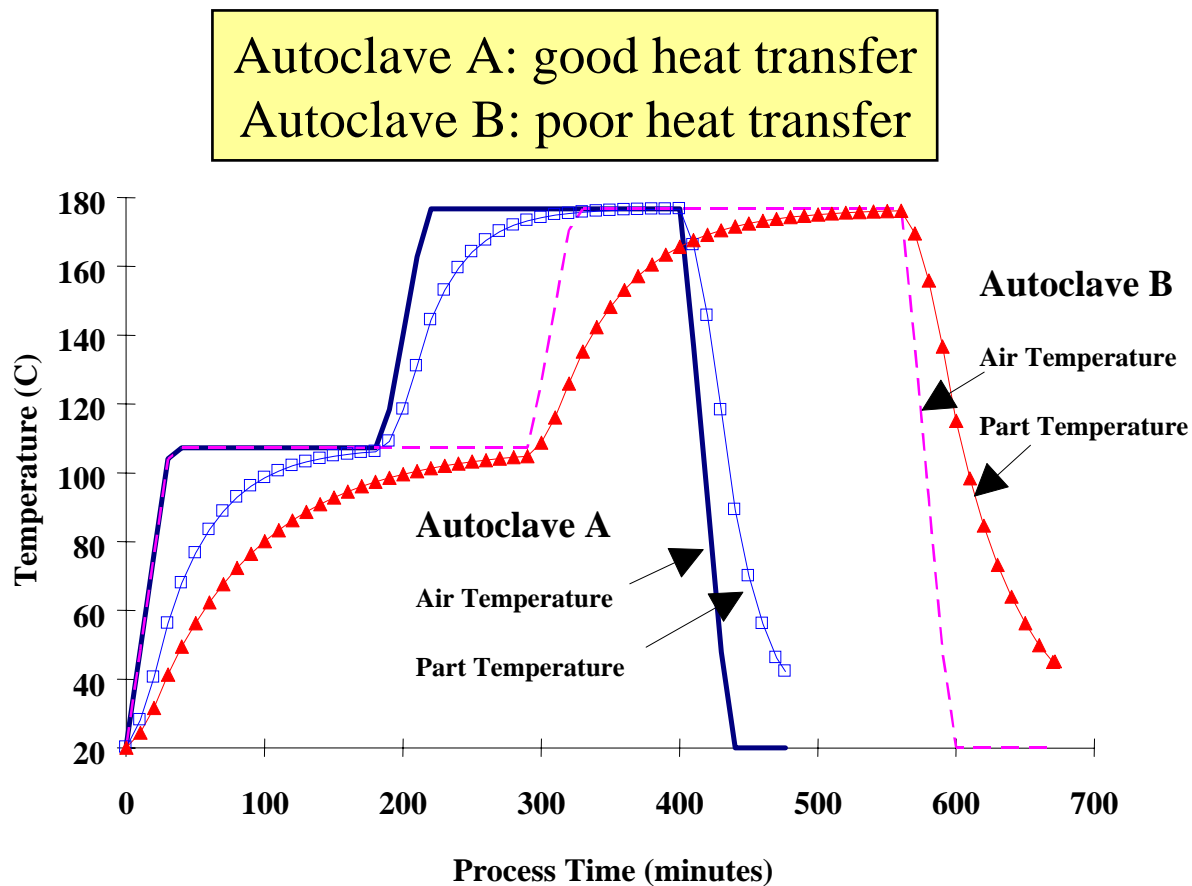

Autoclave heat transfer coefficients (thickness change during cure cycle)

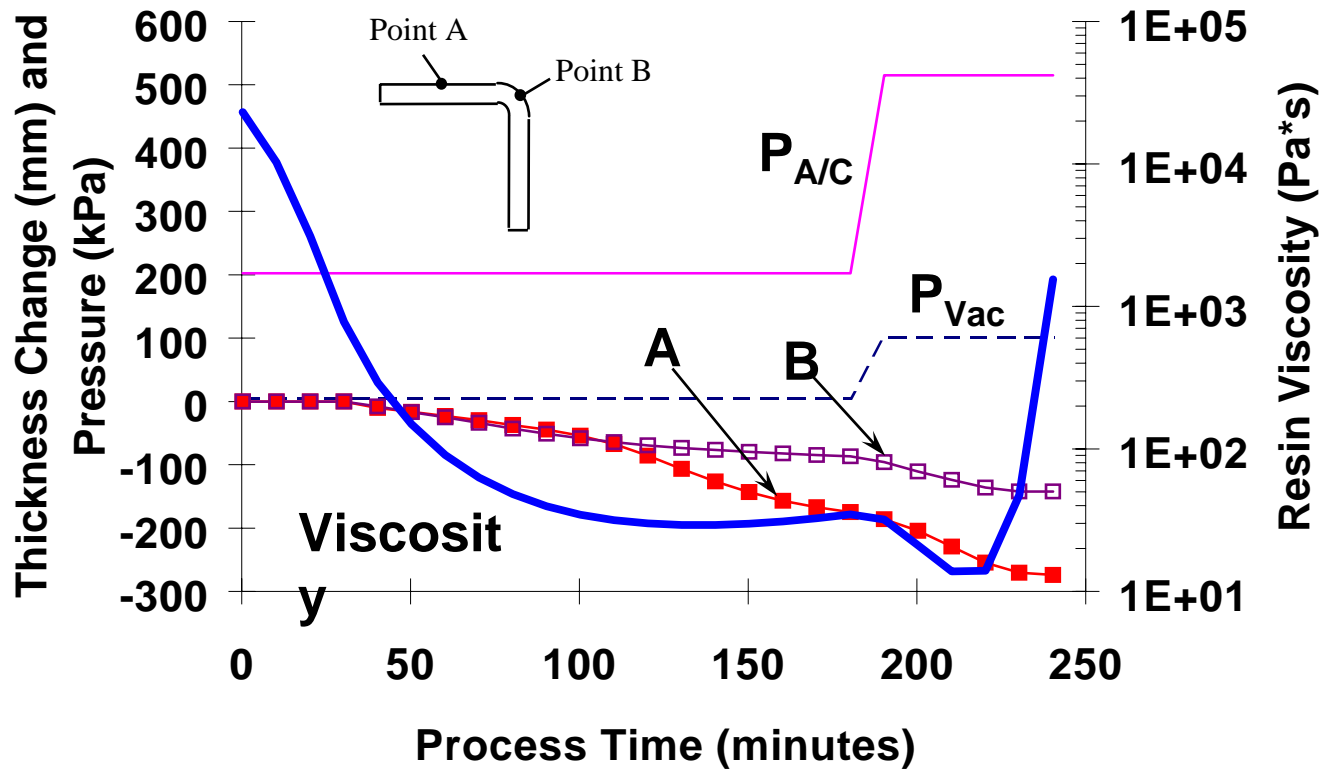

Fibre V_f distribution after cure

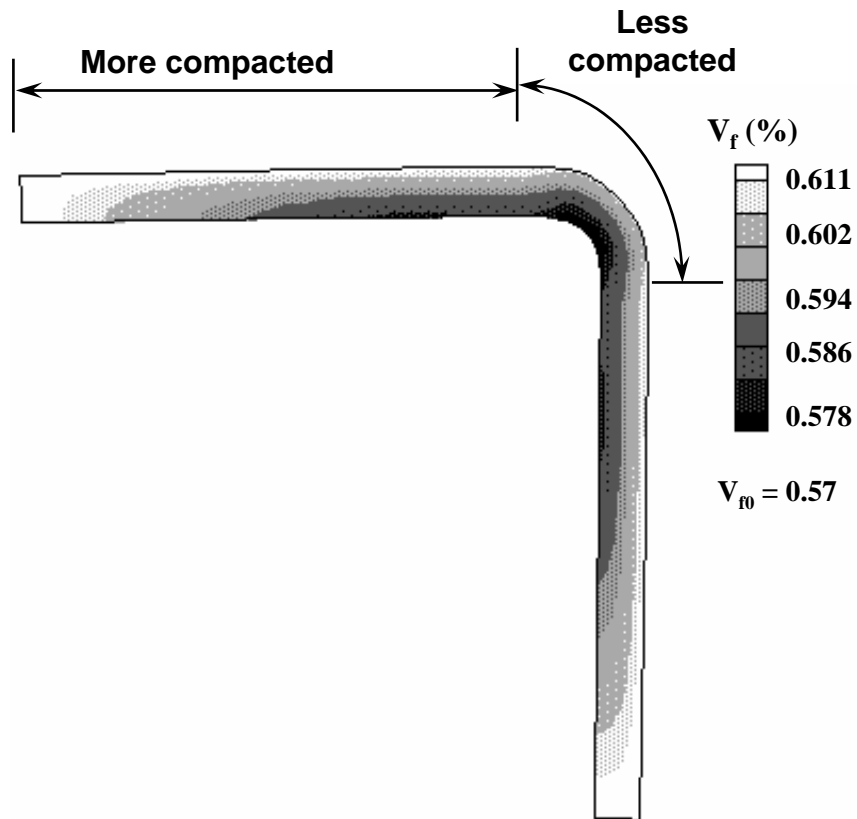

Springback

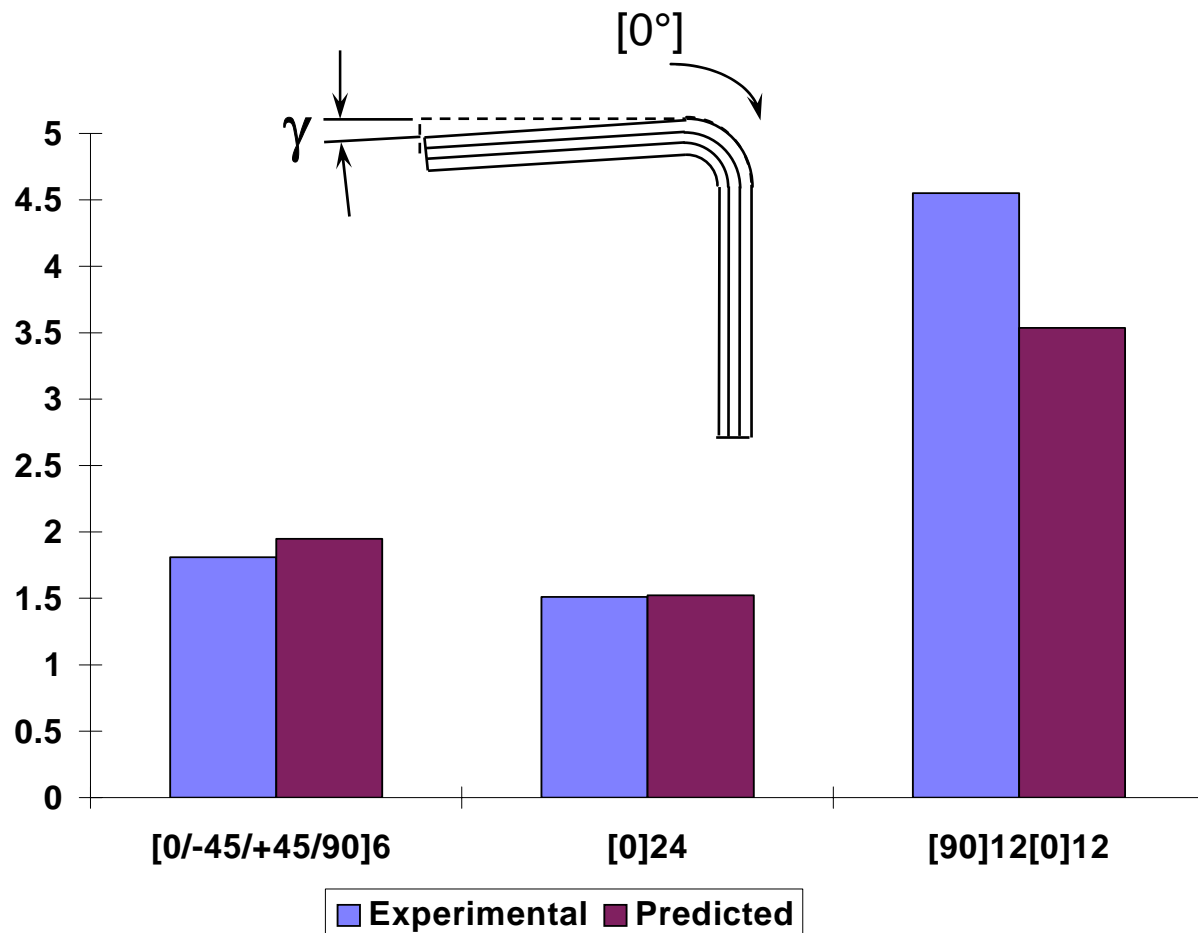

Springback - $[0]_n$ and quasi lay-ups

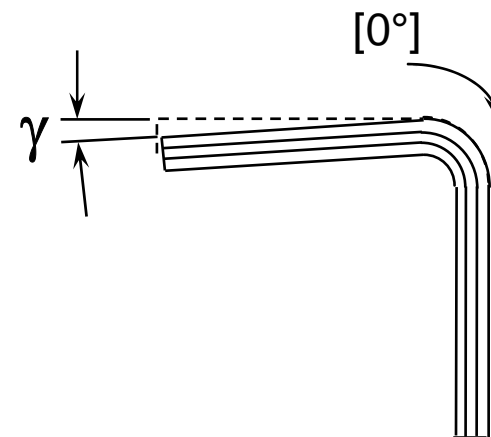
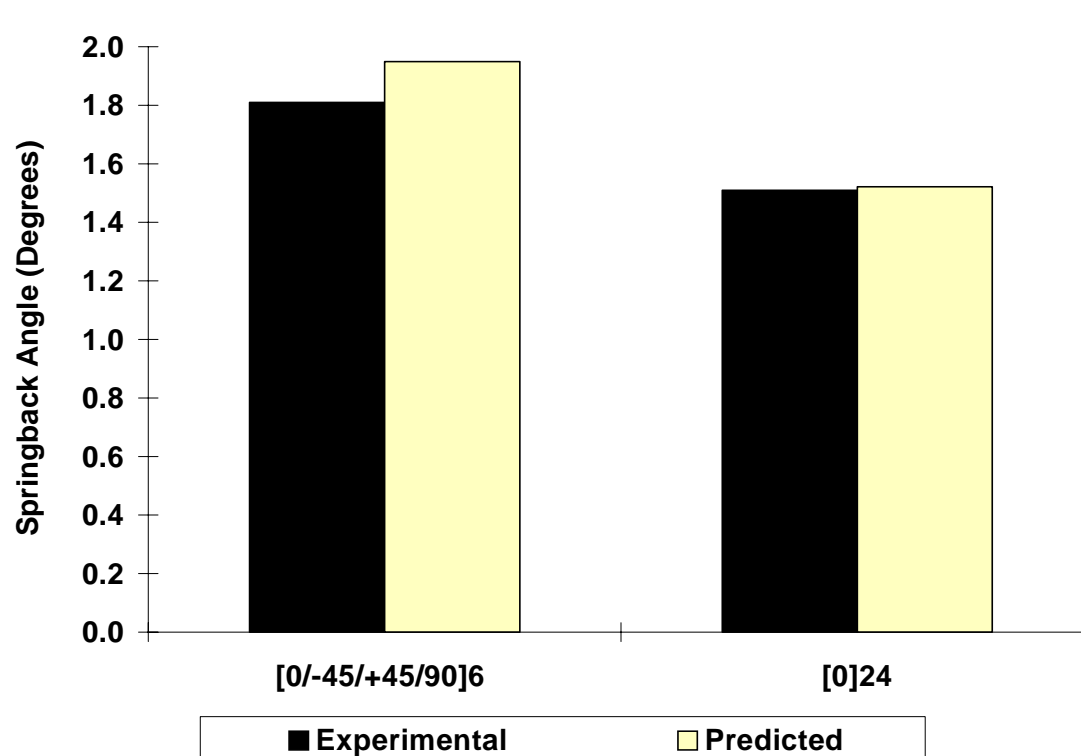

Effect of tool-part interaction and cure cycle on spring-in

- Two parameters: tool-surface condition, cure cycle

Tool and parts

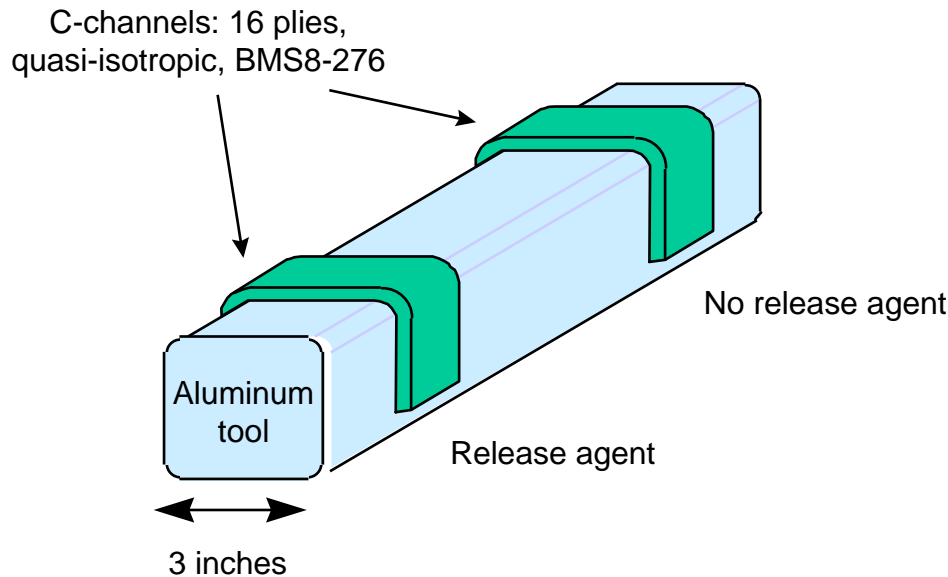

Cure cycles

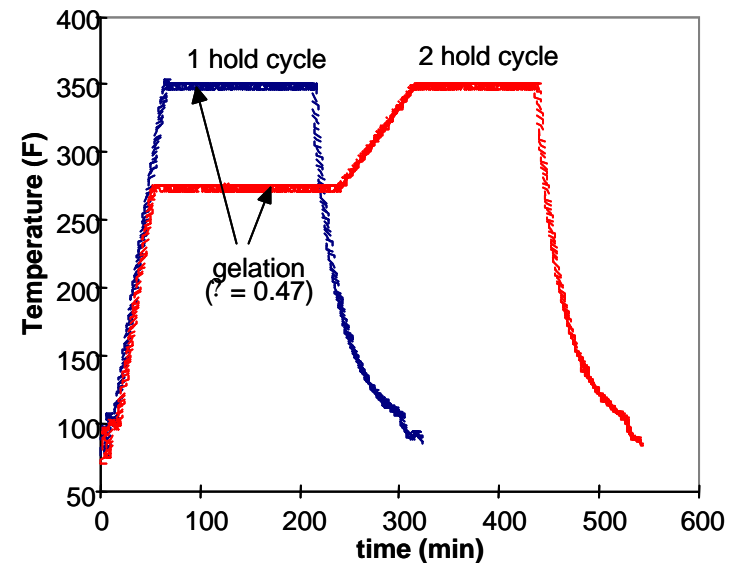

Effect of tool-part interaction and cure cycle on spring-in

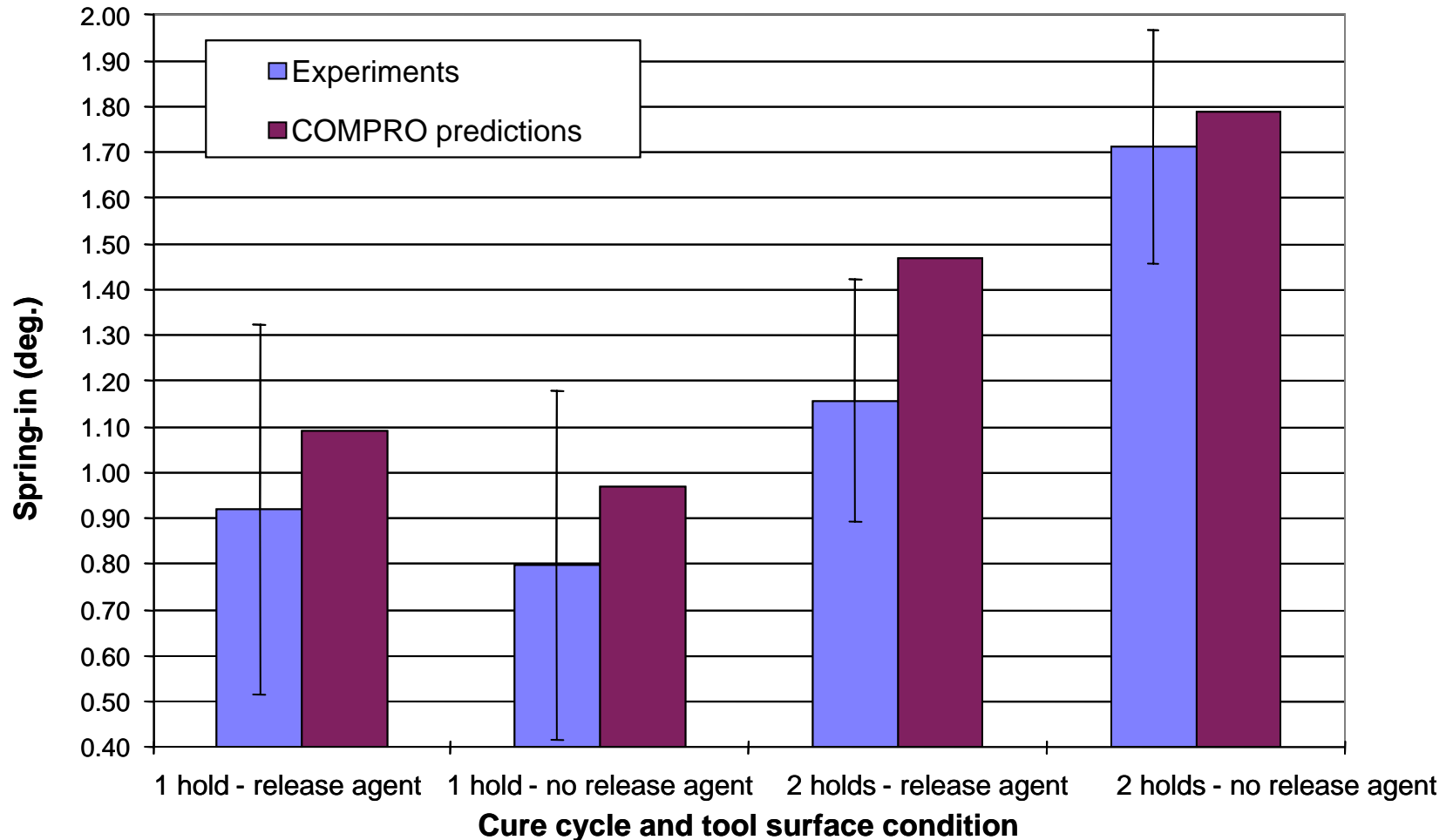

Summary:

Using COMPRO, a study of the effect of tooling material and autoclave heat transfer coefficient is performed. It is found that not all autoclaves are the same and that heat transfer coefficients are pressure dependent. It is shown that the thermal mass of the tool plays a big role in cycle times and that springback is dependent on the cure cycle, but can be predicted with reasonable accuracy using process modelling.

References:

- *Fernelund G, Rahman N, Courdji R, Bresslaur M, Poursartip A, Willden K, Nelson K. [Experimental and Numerical Study of the Effect of Cure Cycle, Tool Surface, Geometry and Lay-Up on the Dimensional Fidelity of Autoclave-Processed Composite Parts](#) - Comp Part A 2002: 33; 341-351